

## ***Manufacturing Reference for Sheet Metal Products***

This reference guide is intended to provide current process capabilities of the sheet metal industry.

The tolerances specified in this document are the minimum available without specialized tooling or processes.

Tolerances should be made as broad as possible, while retaining high product quality and functionality.

Focus should be on maintaining critical quality features.

### **Topics**

- Flatness
- Straightness of Cut
- Squareness
- Edges and Burrs
- Features
- Parallel and Compound Planes
- Bending
  - Right Angles
  - Acute Angles
  - Obtuse Angles
  - Hardware with Configuration Features
  - Measurements from a Bend
  - Bends and Material Grain
  - Minimum Flange
  - Bends/Bend Relief
- Distance of a Punched Hole from a Bend
- Material Thickness and Hole Size
- Distance of a Punched Hole from Edge of Blank
- Finish Classifications

**FLATNESS**

Surface Length	Flatness Tolerance (A)	Surface Length	Flatness Tolerance (A)
In.	In.	Metric (mm)	Metric (mm)
0" # 1.00"	0.005"	0 # 25 mm	0.127 mm
1.00" # 4.00"	0.005"/linear inch	25 # 101.6 mm	5 µm / mm of length
> 4.00"	0.020" +0.004" / in. of length	> 101.6 mm	0.51 mm +4 µm / mm of length

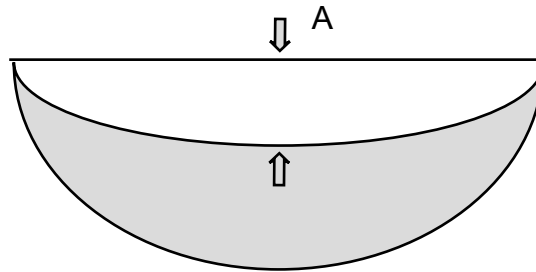

**STRAIGHTNESS OF CUT**

- When measuring the straightness of a cut edge, the maximum deviation from the theoretical straight edge is measured.
- The deviation A shall not exceed .005" per foot (42 µm/cm) of length of cut edge.
- The measurement is to be made along the shear line, not the fracture line.

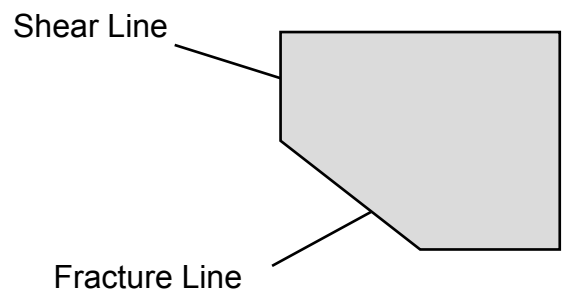
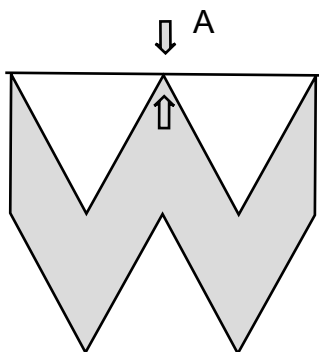

**SQUARENESS**

- To measure the squareness of a cut edge, the length is used as the reference and the width must be square within, B.

☐ Where B is .015 inches per foot (12.5 μm/cm) of width to a maximum of .032 inches (.813 mm) over the entire width.

SQUARENESS BETWEEN	SHEARED EDGE	FORMED EDGE
SHEARED EDGE	0.015" / ft.	0.020" / ft
FORMED EDGE	0.020" / ft	0.015" / ft

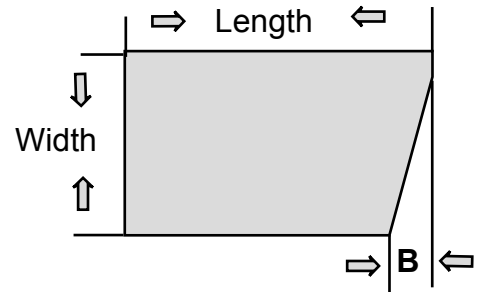

**EDGES AND BURRS**

- Burrs and sharp edges shall be removed to eliminate handling dangers with the following limits:

- ☐ The radius shall not exceed .030 inches (.762 mm), and the chamfer shall not exceed .020 inches (.508 mm) or 10% of the material thickness, whichever is smaller.
- ☐ Localized projections caused by piercing, notching, nibbling, blanking or shearing are permissible but shall not exceed 0.006".

- A sharp edge will be categorized as capable of cutting or scratching a bare hand. Sharp edges should be removed.

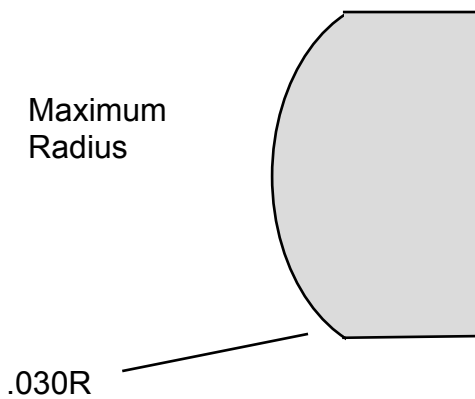

Maximum Chamfer

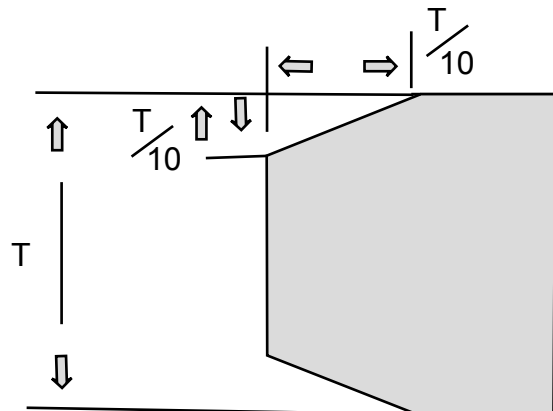

**FEATURES**

**HARDWARE AND CONFIGURATION FEATURES**

SINGLE PLANE

- The following are required tolerances between the individual features found on a single planar unfinished or non-additive finished surface.
- These tolerances will be used unless otherwise stated on the design drawing. Closer tolerances require special operations and increased cost.
- The locations of holes, SCF's\*, and studs\*\* are taken from their center line on the sheared side of the measuring plane.

FEATURES		Tolerances (bilateral)	
		inch	mm
edge to hole	a	0.010	0.254
hole to hole	b	0.005	0.127
hole to SCF	c	0.010	0.254
edge to edge	d	0.010	0.254
hole to stud	e	0.010	0.254
bend to hole	f	0.010	0.254
SCF to stud	g	0.010	0.254
bend to stud	h	0.010	0.254
edge to SCF	i	0.010	0.254
bend to SCF	j	0.010	0.254
bend to edge	k	0.010	0.254
edge to stud	l	0.010	0.254
stud to stud	m	0.010	0.254
SCF to SCF	n	0.010	0.254
bend to bend	o	0.010	0.254

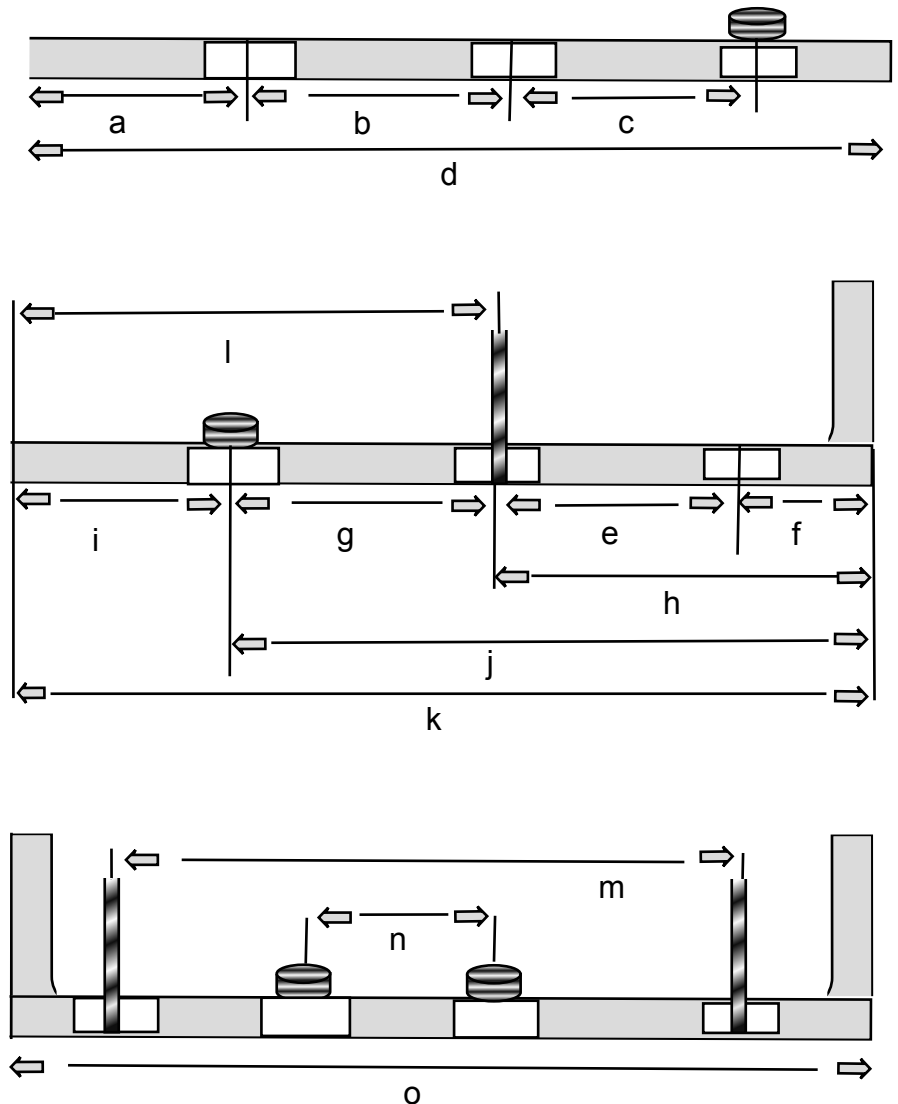

\* SCF = Self Clinching Fastener

\*\* Stud = Stud or Standoff

**FEATURES**

PARALLEL AND COMPOUND PLANE

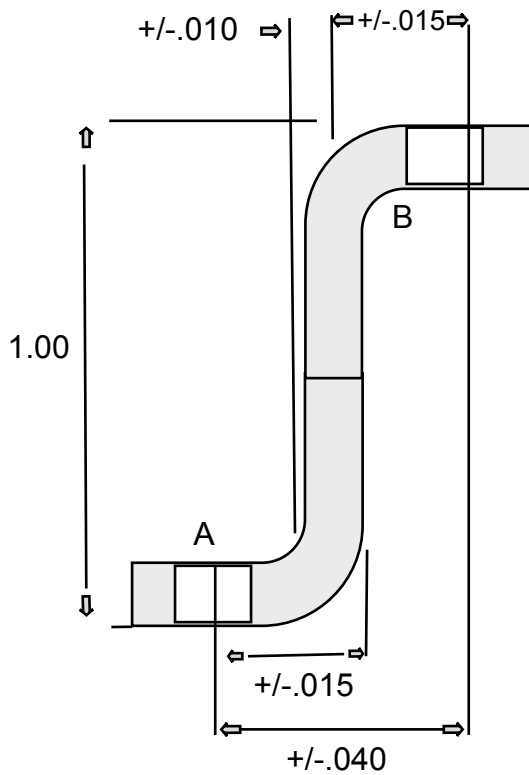

- The tolerance between features on two different parallel planes is the sum of the tolerances between the first feature to the bend, the bend tolerances, and the tolerance between the bend and the second feature.

+/- .015	Hole (A) to Bend
+/- .010	Bend Tol. For 1.00 length
+/- .015	Hole (B) to Bend
<hr/>	
+/- .040	Tolerance between A and B

## BENDING

### RIGHT ANGLES

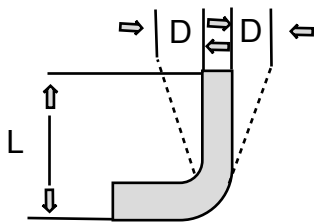

- Angles that are not specified on the engineering drawing and appear to be 90 degrees are considered to be 90 degrees.
- The angular tolerance will be +/- 1 degree.
- The position of material (D) at the end of the bend will vary according to the length of the bend (L).

### ACUTE ANGLES

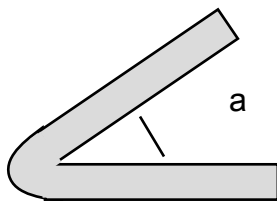

(a < 90 degrees)

### OBTUSE ANGLES

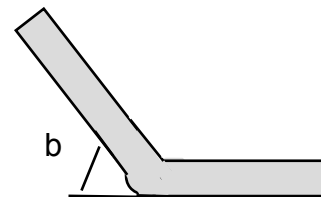

(b < 90 degrees)

- The tolerance for either an acute angle or an obtuse angle is +/- 1 degree regardless of the length of its legs.

## MEASUREMENTS FROM A BEND

### Right and Obtuse Angles:

- The measuring point of a bend shall be established from the outside edge.
- Features are to be measured from the vertical plane that extends from the contact point.
- This plane shall also be used to verify the angle of the bend.

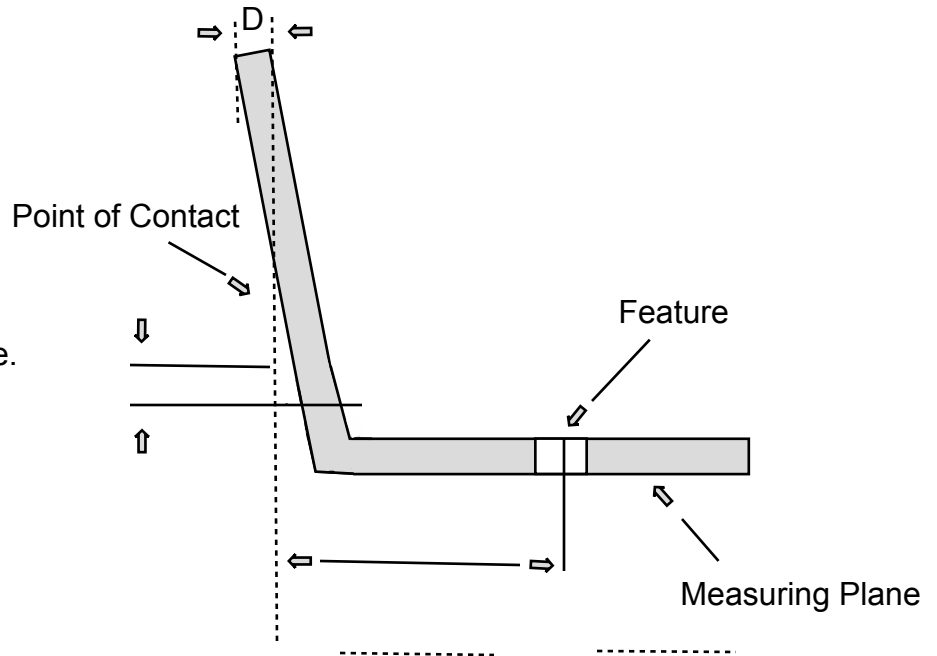

### Acute Angles:

- The position of a feature is measured using a straight edge or cylinder held perpendicular to the measuring plane.

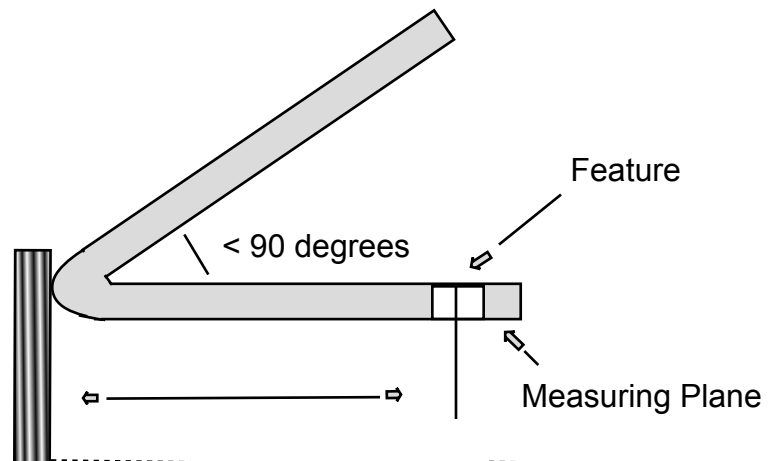

## **BENDS AND MATERIAL GRAIN**

- Whenever the bend configuration permits, a bend shall be made across the grain of the material, or at a 45 degrees to the grain direction.

### **Minimum Flange (Bend Length)**

- The minimum recommended flange dimension should be at least 3.5 times the sum of the material thickness and the bend radius.

## **BEND RELIEF**

- When flanges extend over only a portion of a part, a notch or hole should be provided to prevent tearing (as shown).
- The minimum recommended bend relief will equal the sum of the material thickness and the bend radius.

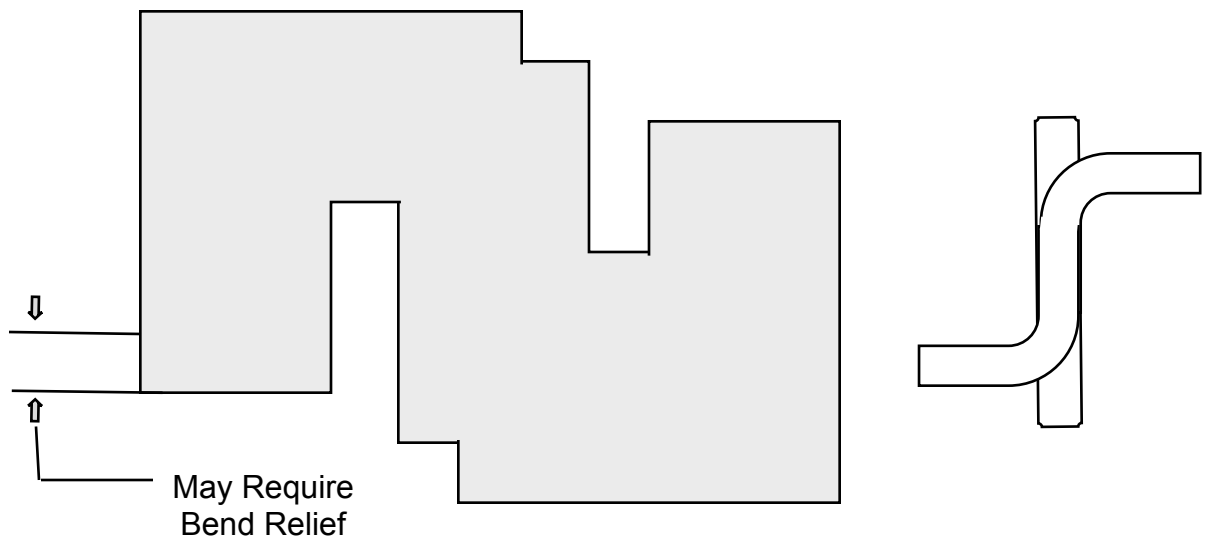



### **DISTANCE OF A PUNCHED HOLE FROM A BEND**

- The minimum inside dimension from a bend to the edge of a punched hole should be 1 1/2 times the sum of the material thickness and the bend radius.
- Punched holes located closer to a bend will tend to distort and may lead to cracking of the material on certain materials.

### **MATERIAL THICKNESS AND HOLE SIZE**

- Generally minimum hole size is limited to the thickness of the material.

### **DISTANCE OF A PUNCHED HOLE FROM EDGE OF BLANK**

- To avoid distortion in sheet metal, holes must not be too close to an edge.
- For sheet metal 1/32 inch or less in thickness, all holes should be at least 1/16 inch from the nearest edge.
- The minimum distance from an edge for thicker material should be twice the thickness, but not less than 1/8 inch.
- The minimum distance between two punched holes should be at least twice the thickness of the material.
- If the holes are to have inserts, studs, etc. pressed in, the manufacturer's recommendations for minimum distances should be observed.

### **DIE/BRAKE MARKS**

- A normal condition that is created during forming of a sheet metal part.
- On internal parts, painted panels, brackets and chassis, brake marks may be acceptable prior to painting.
- The Designer/Engineer is to specify in the drawing notes surfaces which are to be free of tooling marks that are visible with the unaided naked eye.

## **PRE-PLATED METALS AND DEBURRING:**

There are numerous pre-plated metal products on the market today. The most common are:

- Tri-Clear - Appealing cosmetic finish, but the least available of pre-plated metals.
  - Galvanized - Less expensive metal solution, most often requested with min spangled.
  - Galvaneal - Painting and powder coating
  - Loc AF - Good for anti finger print finish.
- 
- It is important when choosing pre-plated material to assess the environmental exposure the product will be subject to.
  - All of these materials caution against deburring, and can not be run through timesaver or stroke sander.

## **FINISH CAPABILITIES:**

### **Paint Masking:**

- From an edge of a part +/- .020 is the minimum that can be held without a special fixture.
- Masking in the middle of the part is held normally to +/- .060 without a special fixture.

### **Powder Coating:**

- Cosmetic conditions such as hiding hardware studs is very difficult in powder coat applications. These desired cosmetic conditions should be avoided or it is recommended the finish be changed to a wet paint process.
- In general it is preferred that masked areas be specified on powder coat instead of general over-spray restrictions, as commonly done with paint. This is due to the nature of powder vs. paint to migrate to any or all unmasked areas. The heat sensitivity of the curing process limits masking jigs & materials.
- Masking large areas is more costly for powder than it would be for paint.
- Products on the market to fill voids etc., do not hold up in the high heat curing process. In addition, these fillers tend to disrupt the grounding required for the powder coat application.

**CENTURY MANUFACTURING and Ty-WOOD CORPORATION FINISH CLASSIFICATIONS:**

**Class "A" Products**

- Decorative or highly visible part.
- Generally intended for customer visible surfaces only.
- Class "A" requirements should be called out specifically.

**Class "B" Products**

- Semi decorative finish.
- Pre finished material can have light fabrication marks which can be covered during the finishing operation.
  - Light fabrication marks are those which cannot catch a fingernail when running across the mark.
- Bending marks are allowed.

**Class "C" Products**

- Customer specifications have not called for decorative characteristics.
- No special handling requirements are expected.

If no class is specified by the customer, the part is considered to be a Class "C".

- Unless otherwise noted on the prints or routing, parts will be viewed or inspected at arms length for 5 - 10 seconds.

**COSMETIC FINISH STANDARD FOR PAINTED AND FINISH PLATED SURFACES**

	<b>Class 1 or "A"</b>	<b>Class 2 or "B"</b>	<b>Class 3 or "C"</b>
<b>1) Class - General Examples</b>	Front of a chassis, enclosure or control panel	Rear of a chassis or enclosure	Interior surfaces of a chassis or enclosure
<b>2) Acceptance Criteria</b>			
<b>Bare metal (unmasked areas)</b>	None	None	None
<b>Scratches (Are not acceptable if through to bare metal)</b>	None	No more than 2 scratches, and not to exceed 1 inch in length per surface.	Not to exceed 1 inch in length
<b>3) Slug Marks</b>	None	No more than 2	Not Critical
<b>4) Coating</b>			
<b>a) Runs</b>	None	1-2 small	Not Critical
<b>b) Blemishes</b>	Slight	Slight	Not Critical
<b>c) Blisters</b>	None	None	None
<b>d) Specks</b>	No more than 2 in a 6 x 6 area	No more than 4 in a 6 x 6 area	Not Critical
<b>e) Coating build-up in corners</b>	None	Slight	1/4" max.
<b>f) Build up on edges</b>	None	Slight	Not critical except in areas that may interfere with assembly
<b>5) Brake Marks</b>	Minimal	Acceptable	Acceptable
<b>6) Silkscreen</b>			
<b>a) Coverage</b>	Complete	Complete	Legible
<b>b) Line Definition</b>	No rough edges	Slight roughness	Moderate roughness
<b>7) Miscellaneous</b>			
<b>a) Hardware</b>	Outline may be visible	Outline may be visible	Outline may be visible

**COSMETIC FINISH STANDARD FOR UNCOATED AND PRE-PLATED SURFACES**

	<b>Class 1</b>	<b>Class 2</b>	<b>Class 3</b>
<b>1) Class</b>	Front of chassis, enclosure or control panel	Rear of chassis or enclosure	Interior surfaces of a chassis or enclosure
<b>2) Acceptance Criteria</b>			
<b>Scratches</b>	None	No more than 2 scratches, not to exceed 1 inch in length	Not Critical
<b>Dings</b>	None	Not to exceed 10% of the material thickness	Not to exceed 20% of the material thickness
<b>Blemishes</b>	None	Slight	Not Critical
<b>Corrosion</b>	None	None	None
<b>Abrasions/Scuff Marks</b>	None	No more than 1 inch in length	Not Critical
<b>Slug Marks</b>	None	No more than 2	Not Critical
<b>Brake Marks</b>	None	Minimum brake marks allowed. Marks must be straight.	Not Critical
<b>Burrs</b>	None	None	None large enough to allow personal injury
<b>Sharp Edges</b>	None	None	None allowed in an area that may cause personal injury.